

Ezy-Wash® CP Lead Safe™ Wall Mtd Exp Mixing Pre-Rinse Unit Type 83 FI Inlet – Pot Filler

PRODUCT CODE:

- 181.10.38.03

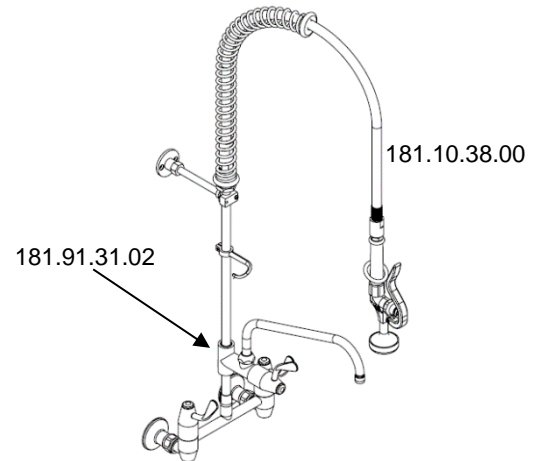

For Watermark and/or WELS information of KITS, refer to each individually certified component.

Item Code:	Description	Watermark	WELS
181.10.38.03	Ezy-Wash® CP Lead Safe™ Wall Mtd Exp Mixing Pre-Rinse Unit Type 83 FI Inlet – Pot Filler	*	*
Components:			
181.91.31.02	Ezy-Wash® CP Lead Safe™ Ezy-Wash Pot Filler Attachment Type 100 J/V 305mm Reach	YES	N/A
181.10.38.00	Ezy-Wash® CP-BS Lead Safe™ Wall Mtd Exp Mixing Pre-Rinse Unit Type 83 FI Inlet - STD	YES	YES

Notes:

1. N/A—Not applicable.
2. * — The item is a **KIT**.
3. A copy of each component's Installation Instructions can either be downloaded from www.galvinengineering.com.au or found inside the packaging.
4. Kit components may be purchased separately.

INSTALLATION

INSTALLATION COMPLIANCE: Galvin Engineering products must be installed in accordance with these installation instructions and in accordance with AS/NZS 3500, the PCA and your local regulatory requirements. Water and/or electrical supply conditions must also comply to the applicable national and/or state standards. Failing to comply with these provisions shall void the product warranty and may affect the performance of the product.

TROUBLESHOOTING

PROBLEM	CAUSE	RECTIFICATION
Dripping water on tap	Jumper valve is worn or damaged	Remove the top assembly, remove debris and /or replace jumper valve if damaged
Water not flowing from tap	Water supply is turned off	Turn on water supply
Dripping water on shower	Headworks are worn or damaged	Remove and inspect the head-works, remove debris and/or replace head parts if damaged
Inconsistent flow	Flow restrictor is blocked	Remove flow regulator from body and remove debris. Install an in-line strainer to stop further blockages.
Leak from behind body	Sealant is insufficient	Apply more sealant
Rate of flow inadequate	The flow restrictor may not be satisfactory due to inadequate supply pressure	Remove flow restrictor and replace with a flow restrictor of different capacity to suit (available from Galvin Engineering)

WARRANTY

Galvin Engineering products are covered under our Manufacturer's Warranty. Galvin Engineering products must be installed in accordance with the installation instructions and in accordance with AS 3500 and NCC Volume Three, relevant Australian Standards and local authorities applicable to product being installed. Water and electrical supply conditions must also comply to the applicable national and/or state standards, failing to comply with these provisions may void the product warranty and affect performance of the product.

Please visit www.galvinengineering.com.au to view the full warranty, our Installation Compliance and Maintenance & Cleaning information as well as any other additional information.